

HIGH SPIN HYGIENIC BARRIER WASHER

FXB
RANGE

FXB 180	FXB 240	FXB 280
18KG 40LB	24KG 55LB	28KG 70LB



FEATURES

- Freestanding, high spin
- Complete stainless steel cabinet
- Xcontrol Plus - Fully programmable
- Stainless steel drum and tub
- Large drain valve (Ø 76 mm)
- Easy access to all important parts from all sides
- Large door opening for easy loading & unloading
- Automatic door positioning
- Easy Soap - liquid soaps connection
- External lubrication system
- Patented inner door lock

OPTIONS

- USB & RS485 plug (on the side panel)
- Liquid soap pumps
- Water recovery option incl. second drain valve
- Steam heating version
- Water sample tap
- Trace-Tech® traceability software and networking system
- Second display
- Extra signalization (orange light or traffic light)

TRACE-TECH

OPTILOAD

XCONTROL+

supereco
washing programmes



ERGONOMICAL
CONSTRUCTION



LARGE DOOR
OPENING



LOW WATER
AND ENERGY
CONSUMPTION

GET AHEAD IN LAUNDRY+

TYPE		FXB180	FXB240	FXB280
CAPACITY				
Drum capacity	kg/lb	18/40	24/55	28/65
Drum volume	l	180	240	280
Drum diameter	mm	Ø 750	Ø 750	Ø 750
Number of drums		1	1	1
Number of loading doors		1	1	1
Number of unloading doors		1	1	1
DRUM SPEED				
Washing speed	rpm	42	42	42
Highest spin speed	rpm	939	939	914
G-FACTOR				
		370	370	350
PROGRAMMER				
XControl Plus		standard	standard	standard
CABINET				
Stainless steel		standard	standard	standard
HEATING				
Electricity (standard)	kW	12/18	18	21,9
Steam	bar	3-8	3-8	3-8
CONNECTIONS				
Electrical		3x 200-240V 50/60Hz 3x 380-480V 50/60Hz		
Water inlet		3x DN20 3/4"		
Steam inlet		1x DN15 1/2"		
DIMENSIONS				
Size H×W×D	mm	1455×900×1145	1455×1020×1145	1455×1130×1145
Net weight	kg	430	460	490
TRANSPORT DATA				
Packed H×W×D	mm	1610×1010×1235	1610×1130×1235	1610×1240×1235
Gross weight	kg	485	515	550

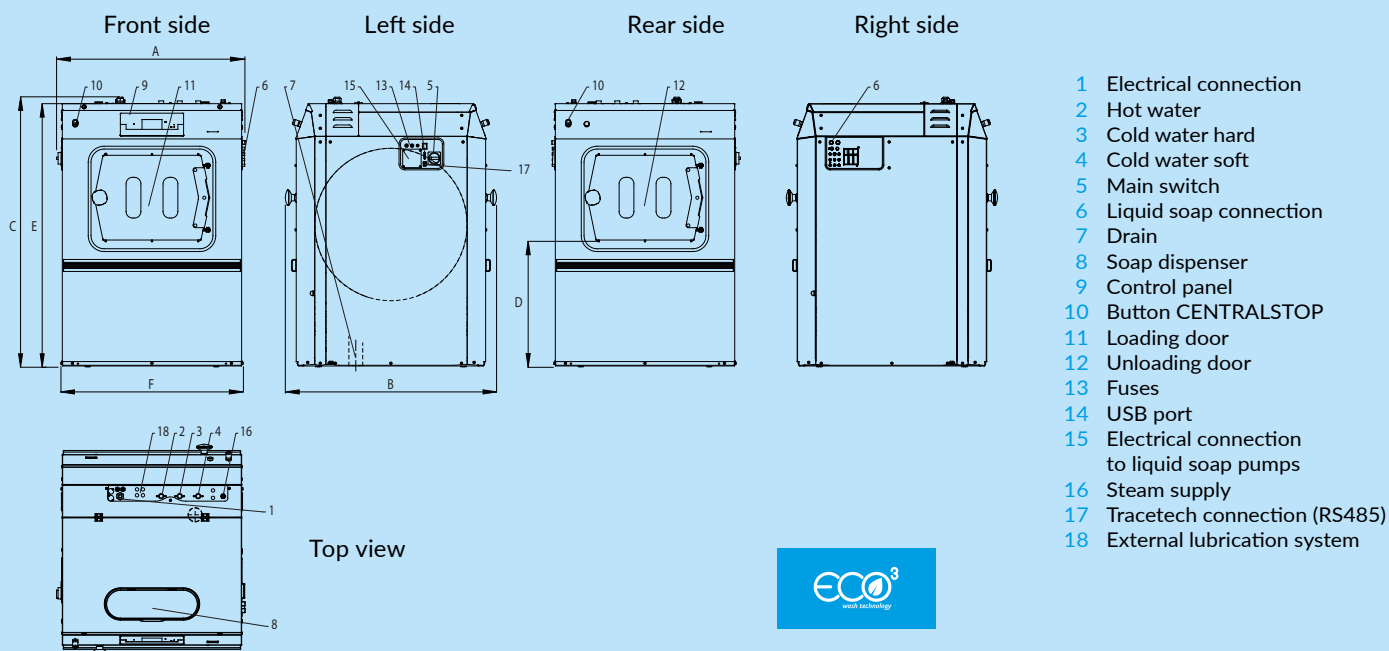

DIMENSIONS

	A	B	C	D	E	F
FXB180	900	1145	1455	655	1423	850
FXB240	1020	1145	1455	675	1423	970
FXB280	1130	1145	1455	670	1423	1080
	width	depth	height			

DIMENSIONS DOOR DIMENSIONS

	height	width
FXB180	325	376
FXB240	325	496
FXB280	325	496

The Primus preserves the right to change the machines and the specification in this leaflet at any time, without prior notice. Details and photographs are only for information and never binding.

www.primuslaundry.com

Primus by Alliance Laundry Systems

