

HIGH EFFICIENT RIGID MOUNTED INDUSTRIAL WASHER EXTRACTORS

RX
RANGE

RX 180	RX 240	RX 280
18KG 40LB	24KG 53LB	28KG 62LB



FEATURES

- Rigid mounted, normal spin, 100G factor
- Stainless steel top and front panel, black side panels
- Stainless steel drum and tub
- XControl - easy to use microprocessor
- Patented soap hopper
- High capacity water inlets (RX280)
- Large drain valve (Ø 76 mm)
- Easy access to all vital parts from the front
- Large door opening for easy loading & unloading

OPTIONS

- 200G factor execution
- XControl+ Fully programmable
- Coin operated timer
- Stainless steel side panels
- USB plug (on the back panel)
- Liquid soap connection
- Liquid soap pumps
- Water recovery kit
- Steam heating version
- 3rd water inlet
- High capacity water inlets (RX180, RX240)
- ECO version : lower kW rating on request



ERGONOMIC
CONSTRUCTION



LARGE DOOR
OPENING



LOW WATER
AND ENERGY
CONSUMPTION

cascade
drum

TRACE-TECH

OPTILOAD

XCONTROL

supereco
washing programmes

GET AHEAD IN LAUNDRY

TYPE		RX180	RX240	RX280
INNERDRUM				
Capacity 1:09	kg (lb)	20(44)	27(60)	31(68)
Capacity 1:10	kg (lb)	18(40)	24(53)	28(62)
Volume	litres	180	240	280
Diameter	mm	750	750	750
DRUM SPEED				
Wash	rpm	42	42	42
Extraction	rpm	490 (690)*	490 (690)*	490 (690)*
G-FACTOR				
		100 (standard) 200*	100 (standard) 200*	100 (standard) 200*
HEATING				
ELECTRICITY (KW) very low-low-std-higher-special 1 -2-3	kW	----std 12 - higher 18-----	----std 18-----	----std 21,9-----
Steam	bar	1-8	1-8	1-8
Hot water	°C	90	90	90
Sound pressure level	dB (A)	< 65	< 65	< 65
Water valves connection	BSP	3/4"	3/4"	3/4"
Water pressure	kPa	100-800	100-800	100-800
Rec. water pressure	kPa	300-500	300-500	300-500
Water inlet	l/min	20	20	20
Drain valve	outer Ø mm	76	76	76
Flow amount with drain valve	l/min	210	210	210
Steam valve connection	BSP	1/2"	1/2"	1/2"
Steam pressure	kPa	100-800	100-800	100-800
DIMENSIONS				
Size H×W×D	mm	1410×890×915	1410×890×1060	1410×890×1135
Net weight	kg	255 (315)*	275 (330)*	290 (355)*
TRANSPORT DATA				
Packed H×W×D	mm	1550×925×970	1550×925×1130	1550×925×1190
Gross weight	kg	270 (335)*	290 (355)*	305 (385)*

* 200 G-factor execution

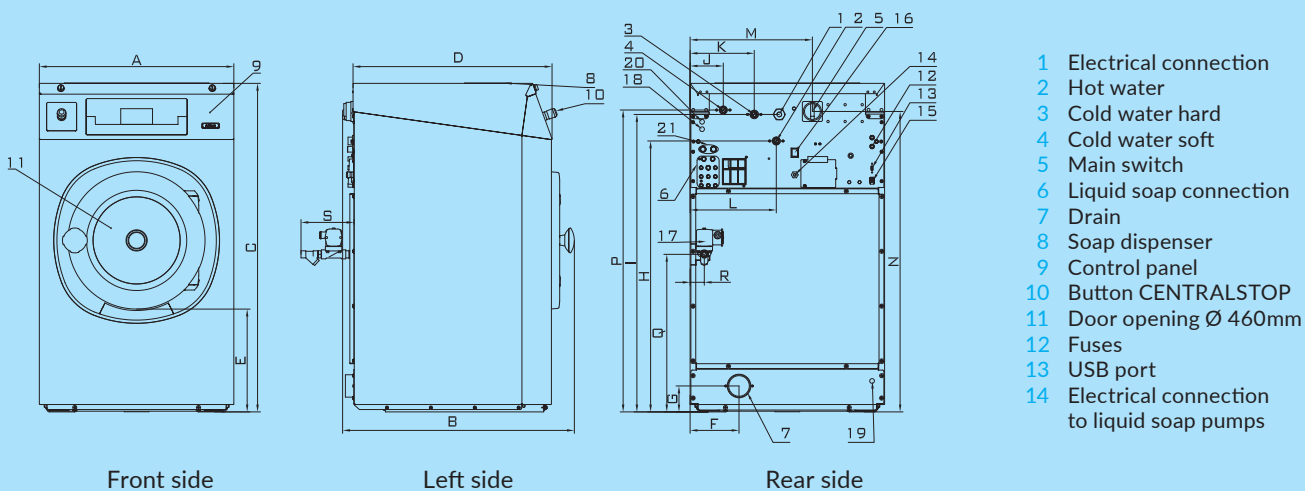

DIMENSIONS

	A	B	C	D	E	F	G	H	I	J	K	L	M	N	P	Q	R	S
RX180	890	915	1410	815	465	280	130	1212	1297	113	218	303	625	1270	1317	528	54	120
RX240	890	1060	1410	960	465	280	130	1212	1297	113	218	303	625	1270	1317	528	54	120
RX280	890	1135	1410	1035	465	280	130	1212	1297	113	218	303	625	1270	1317	528	54	120
	width	depth	height															



The Primus preserves the right to change the machines and the specification in this leaflet at any time, without prior notice. Details and photographs are only for information and never binding.
www.primuslaundry.com



Primus by Alliance Laundry Systems