

# HIGH SPIN HYGIENIC BARRIER WASHER EXTRACTORS



**MXB  
RANGE**

MXB 360	MXB 500	MXB 700
36KG 79LB	50KG 110LB	70KG 154LB



## FEATURES

- Freestanding, high spin
- Oversized frame, bearings and drum
- Large drain valves (2 x Ø 76 mm)
- Easy access to all parts
- Frequency controlled motor
- Large door opening for easy loading and unloading
- Perforated lifting ribs: more mechanical action, lower water consumption
- Eco-friendly washing programs - significantly reduces water and electricity consumption
- USB & RS485 plug
- Soap dispenser with 5 removable compartments
- Designed with focus on ergonomics
- Patented Cascade Drum
- Golden lock - patented inner door lock mechanism

## OPTIONS

- Liquid soap pumps
- Insulation for energy, heat and noise reduction
- Version without soap hopper
- Drain valve for water recycling
- Water sample tap
- Air operated water inlets
- Pullman or clean room
- Second display (located on the clean side)
- Lateral drain
- Extra visualisation of end of cycle (orange light + signal)
- Extra visualisation of end of cycle (traffic light + signal)
- OptiLoad® - Weighing system
- Automatic weighing system through 4 weighing cells
- Tilting system: assists operators during loading & unloading

## XCONTROL FLEX PLUS PLATFORM

- 7", full colour touch screen display with swipe function: very intuitive for users
- User-friendly screen with operating instructions built in as part of the control
- Complete control content available in 34 languages
- Wireless communication enabling programming
- Automated service reminders remind users to maintenance tasks
- i-Trace laundry management software for a perfect control of your laundry installation



XControl FLEX PLUS approach, program, and cycle screens



**GET AHEAD** IN LAUNDRY

\*Consult your sales representative for availability

TYPE		MXB360	MXB500	MXB700
<b>CAPACITY</b>				
Drum volume	l	360	500	700
Capacity 1:09	kg (lb)	40(88)	55,5(122)	78(172)
Capacity 1:10	kg (lb)	36(79)	50(110)	70(154)
Drum diameter			775	
Drum depth	mm	764	1060	1484
Drum type			Cascade	
Number of drums		1	1	2
Number of loading doors		1	1	2
Number of unloading doors		1	1	2
<b>MOTOR</b>				
Power	kW	4		7,5
<b>DRUM SPEED</b>				
Wash speed	rpm		41	
Extraction speed	rpm		900	
<b>G-Factor</b>				
			350	
<b>PROGRAMMER</b>				
XControl FLEX PLUS			standard	
<b>CABINET</b>				
Door opening angle			155	
<b>HEATING</b>				
100% hot water	°C		90	
100% electrical	kW	36	48	60
Steam high pressure	bar		3-8	
<b>CONNECTION</b>				
Electrical			3x 200-240V 50/60Hz 3x 380-415V 50/60Hz 3x 440-480V 50/60Hz	
Water inlet	in		3x 1"	
Steam inlet	in		3/4"	
Drain diameter	in		2x 3"	
<b>DIMENSIONS</b>				
H×W×D	mm	1700 x 1270 x 980	1700 x 1566 x 980	1700 x 2032 x 980
Net weight	kg	960	1130	1310
<b>TRANSPORT DATA</b>				
Packed H×W×D	mm	2005x1530x1255	2005x1830x1255	2005x2290x1255
Gross weight	kg	1090	1280	1470

36 / 50 kg

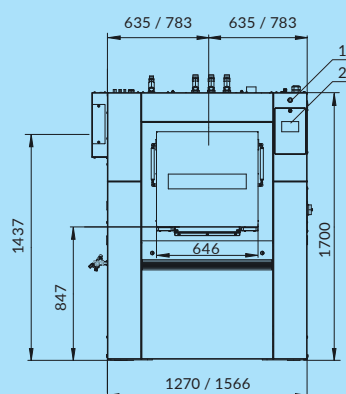

70 kg

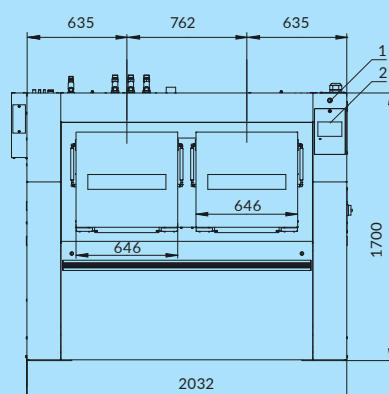

36, 50, 70 kg

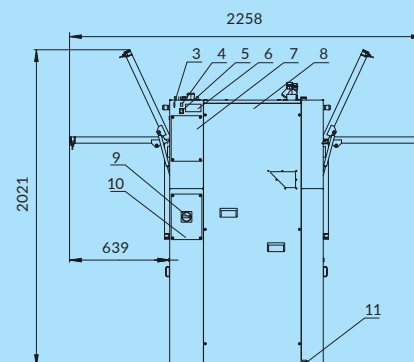

- 1 Emergency stop
- 2 Control panel
- 3 USB Port
- 4 PC Programming Connection

- 5 Switch: Steam / Electric Heating
- 6 Serial Plate
- 7 Electrical Signals Liquid Soap Cover
- 8 Electrical Components with Frequency Inverter Cover

- 9 Main Switch Cover
- 10 Main Switch
- 11 Equipotential Bounding Terminal

The Primus preserves the right to change the machines and the specification in this leaflet at any time, without prior notice. Details and photographs are only for information and never binding.  
www.primuslaundry.com

