

DRYING CABINET

DC
RANGE

DC 8

DC 16

8KG
17LB

16KG
36LB



FEATURES

- Very low energy consumption, only 0,5 kWh/kg, very short drying time, 42 minutes (DC8).
- Four automatic programs and one program for time dry
- HTS - measures the level of humidity every single second, to determine exactly when the textiles are dry.
- 16m (DC8), 32m (DC16) hanging length
- Double overheat-protection for increased security.
- The top is removable for easier handling and installation.
- Test program and error codes make it easier for maintenance
- Double sheet metal in sides and doors minimize loss of energy
- Hanging frame can be rotated 90° (DC16), 180° (DC8)
- Three fans (2x DC8) create perfect balance between evacuated and re-circulated air
- Service menu with possibilities to adjust the function of the cabinet
- CE approved.

OPTIONS

- Single rack bar, instead of swinging rail
- Kit of 3 hook racks
- Hanging rails
- Single bar clothes hanger

MARKETS

Laundries, Laboratory, Fire brigades, Police stations, Army, Airports, Campings, Golf clubs, Football clubs, Diving schools, Theatres, Spas, Horse farms, Oil platforms, Ski resorts, Fish industries, Marines, Ships

MAIN SPECIFICATIONS		DC8	DC16
Loading capacity	kg/lbs	up to 8 /17,6	16
Drying capacity	g/min	62*	81**
Hanging length	m/feet	16	30
Drying time	min	42*	64**
Evacuated air	m ³ /h	340 (max)	550
Heating effect	kW	6	9
Total effect	kW	6,3	9,45
Energy consumption /kg	kWh	0,5	0,54

* Drying of 6 kg cotton (dry weight), washed and high-spun to 43% residual moisture, dried to 0% residual moisture.

** Drying of 12 kg cotton (dry weight), washed and high-spun to 43% residual moisture, dried to 0% residual moisture.

TECHNICAL SPECIFICATIONS		DC8	DC16
ELECTRICAL CONNECTIONS			
Standard electrical connection		380-415V/50/60Hz/3phase + N	380-415V/50/60Hz/3phase + N
Fuse	A	10	16
Total effect	kW	6,3	9,45
Heating elements	kW	6	9
AIR CONNECTIONS			
Outlet exhaust	Ø mm/inch	125/4,92	160
Outlet air flow	m ³ /h	230	300
Pressure drop	max Pa	70	260
SOUND LEVEL			
Airborne sound level	dB(A)	62	65
SHIPPING DATA			
Net	kg/lbs	145/319,7	235/518
Crated	kg/lbs	14/31	40/88,2
Shipping data net	kg/lbs	159/350,5	275/606
Shipping volume	m ³	1,78	1,76
OPTIONAL ACCESSORIES			
Single bar	part number	POD131070	POD131072
Hook rack, set of three	part number	POD131071	POD131071
DIMENSIONS			
Width	mm/inch	1200/47,2	1800/71
Depth	mm/inch	640/25,2	800/31,5
Height	mm/inch	1870/73,6	1955/77

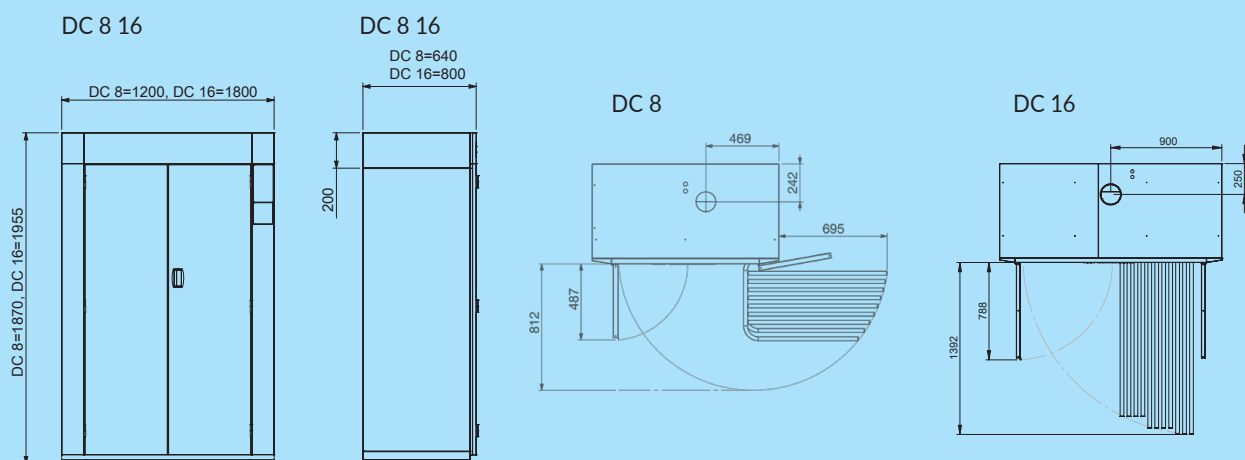

The Primus preserves the right to change the machines and the specification in this leaflet at any time, without prior notice. Details and photographs are only for information and never binding.

www.primuslaundry.com



Primus by Alliance Laundry Systems