

# PROFESSIONAL COMPACT WASHER EXTRACTOR PROFESSIONAL COMPACT DRYER

| SC<br>RANGE | SC 70       | SC 90       |
|-------------|-------------|-------------|
|             | 6KG<br>13LB | 9KG<br>18LB |

| DAM<br>RANGE | DAMV7       | DAMC7       | DAM7 HP     | DAMV9       |
|--------------|-------------|-------------|-------------|-------------|
|              | 7KG<br>14LB | 7KG<br>14LB | 7KG<br>14LB | 8KG<br>17LB |



## SC70, SC90 WASHER-EXTRACTORS FEATURES

- Titanium grey cabinet
- Stainless steel drum and tub
- Easy to use timer with color Display
- Available in 25 languages
- Up to 50 programs (including Mop & Medical programs)
- 3 Soap compartments
- Matching dryer available – space saving when placed on top
- Available with pump or drain valve
- Marine voltages available (SC70)

## DAMV7, DAMC7, DAM7 HP, DAMV9 Dryers features

- Titanium grey cabinet
- Reversing drum
- Stainless steel drum
- Large door opening (Ø 45 cm)
- Available in 25 languages
- Easy to use timer with color Display
- Available with vent heating (DAMV7 & DAMV9), condenser unit (DAMC7) or heat pump heating (DAM7 HP)
- Marine voltages available (DAMV7)

## ACCESORIES (WASHERS & DRYERS)

- Wifi Modules to connect to Wi-Fi & Connect Life
- Kit to connect to Central Pay System
- Connectivity to external systems
- Marine fixing brackets to avoid tilting of machine

## CONNECTIVITY (WASHERS & DRYERS)

- Wi-fi connectivity via accessory. Monitor the status of the machine: usage of the machine, machine status, failure codes, logging of programs. Update the program

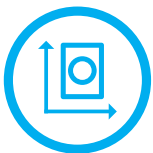

COMPACT  
DESIGN



STACKABLE  
UNIT



ENERGY  
EFFICIENT

| TYPE                       |       | SC70  | SC90                                    |
|----------------------------|-------|---|---|
| DRUM VOLUME                | l     | 60  | 80                                      |
| CAPACITY 1:9               | kg/lb | 7/15  | 9/20                                    |
| CAPACITY 1:10              | kg/lb | 6/13  | 8/18                                    |
| DRUM DIAMETER              | mm    | Ø 480   |   |
| EXTRACTION SPEED           | rpm   | 1400  |   |
| G-FACTOR                   |       | 530   |   |
| Residual moisture          | %     | 49  | 49                                      |
| Sound (wash, spin) 1400rpm | dB(A) | 61-76   | <72                                     |
| ELECTRICAL CONNECTION      |       | With drainpump:<br>208-240V/60/1<br>380-415V/50/3Ph+N*<br>440V/60/2Ph-N | 400V/50hz/3ph                           |
| ELECTRICAL HEATING         | kW    | 3,0 (4,4 Marine)  | 4,4                                     |
| CIRCUIT BREAKER            |       | 230V-16A/400V-10A   | 400V-10A                                |
| WATER CONNECTION           | inch  | 3/4"  | 3/4"                                    |
| DRAIN                      |       | Pump Standard,<br>Drain valve available                                 | Pump Standard,<br>Drain valve available |
| DIMENSIONS                 |       |   |   |
| HxWxD                      | mm    | 850x595x590   | 850x595x706                             |
| Net weight                 | kg    | Pump:76,5<br>Valve: 77,0  | Pump: 92,0<br>Valve: 92,5               |
| TRANSPORT DATA             |       |   |   |
| Volume (packed)            | m3    | 0,39  | 0,46                                    |
| Packed HxWxD               | mm    | 920x640x661   | 920x640x776                             |

## WASHER

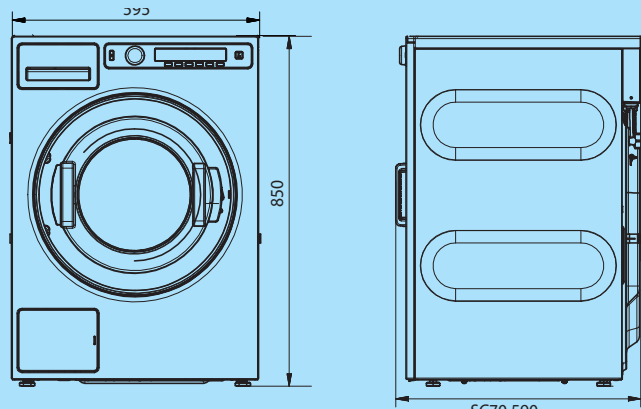

| TYPE                  |       | DAMV7<br>vent                                       | DAMC7<br>condenser | DAM7HP<br>Heat Pump | DAMV9<br>Vent                   |
|-----------------------|-------|---|--------------------|---------------------|---------------------------------|
| CONTROL TYPE          |       | Electronic Display                                  |                    |                     |                                 |
| DRUM VOLUME           | l     | 117   |                    |                     | 145                             |
| CAPACITY 1:18         | kg/lb | 7/14  |                    |                     | 8/18                            |
| CAPACITY 1:22         | kg/lb | 5/12  |                    |                     | 7/15                            |
| DIMENSIONS DRUM       | mm    | Ø 571x476   |                    |                     |                                 |
| ELECTRICAL CONNECTION |       | 208-240V/60/1<br>380-415V/50/3Ph+N<br>440V/60/2Ph-N | 380-415/50/3Ph+N   | 208-240V/50/1Ph     | 380-415/50/3+n<br>230V/50Hz/1ph |
| ELECTRICAL HEATING    | kW    | 3   | 2,5                | 0,9                 | 4,4                             |
| CIRCUIT BREAKER       |       | 230V-16A<br>400V-10A                                |                    | 230V-10A            | 400V-16A                        |
| AIRFLOW               | m3/h  | 245   | 123                | internal            |                                 |
| AIR EVACUATION        | mm    | 100   | -                  | -                   |                                 |
| DIMENSIONS HxWxD      | mm    | 850x595x654   |                    |                     | 850x595x769                     |
| Net weight            | kg    | 40  | 45                 | 57                  | 43,6                            |
| TRANSPORT DATA        |       |   |                    |                     |                                 |
| Volume (packed)       | m3    | 0,43  |                    |                     | 0,49                            |
| Packed HxWxD          | mm    | 920x640x723   |                    |                     | 920x640x838                     |
| Gross weight          | kg    | 44,4  | 49,4               | 61,4                | 48,2                            |

## DRYER

