

CHEST HEATED IRONERS - ONE ROLL

ACL370

ACL
RANGE



FEATURES

Chest

- Single piece super flexible laser welding chest have 180-206° wrap up contact to rolls
- Self-adjusted chest applies pressure always equally over entire width and length of the roll. To make linen being ironed equal quality.
- Heated by circulated thermal oil moving in the chest. It makes the temperature even along full chest width. No trouble of overheated spots.
- Self-contained thermal oil heating and circulation system offers accurate temperature control, easy installation and start up

Delivery

- Front return to save operation space and one person to operate
- Rear return to connect folder when necessary
- Front and rear return optional to be flexible to suit the laundry flow

Roll

- Perforated steel roll with under springing and polyester felt 800 gr/m² padding
- Suction through the roll to ventilate moisture
- Fully enclosed planetary gearbox mounted directly onto the roll
- Variable speed by frequency inverter drive

Control

- Simple readout control to set temperature and speed manually

OPTIONS

- Higher ironing speed
- Longer feeding table
- Foot pedal
- M-Aramid padding

TYPE		ACL370-17	ACL370-20	ACL370-22	ACL370-25	ACL370-30
Roll diameter	mm			370		
Working width	mm	1750	2000	2200	2500	3000
Ironing speed	m/min			1-6,5		
Fan motor	kW			0,25		
Roll motor	kW		0,37		0,5	
Air outlet diameter	mm			Ø75		
Hydraulic pump motor	kW			0,37		
Oil circulation pump	kW			2,2		
Voltage		380-415V/50Hz/3ph+TN-C				
GAS HEATING						
Gas connection	inch			1/2"		
Gas pressure	mbar			20		
Gas consumption	kW	25	28	31	35	42
Heat exchanger e vacuation	mm			Ø90		
Ironing capacity @moisture retention 50%	kg/hr	48	54	60	67	81
ELECTRIC HEATING						
Heating element	kW		30		35	40
Ironing capacity @moisture retention 50%	kg/hr	48	54	60	67	81
DIMENSIONS						
H×W×D	mm	1200x2474x1520	1200x2724x1520	1200x2924x1520	1200x3224x1520	1200x3724x1520
Net weight	kg	700	782	862	983	1203
TRANSPORT DATA						
Packed H×W×D	mm	1300x2574x1050	1300x2824x1050	1300x3024x1050	1300x3324x1050	1300x3824x1050
Gross weight	kg	730	812	892	1013	1233

ACL370 - FRONT RETURN - ELECTRIC HEATING

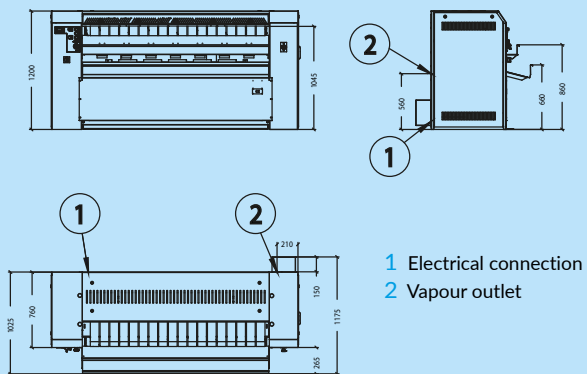

- 1 Electrical connection
- 2 Vapour outlet

ACL370 - REAR RETURN - ELECTRIC HEATING

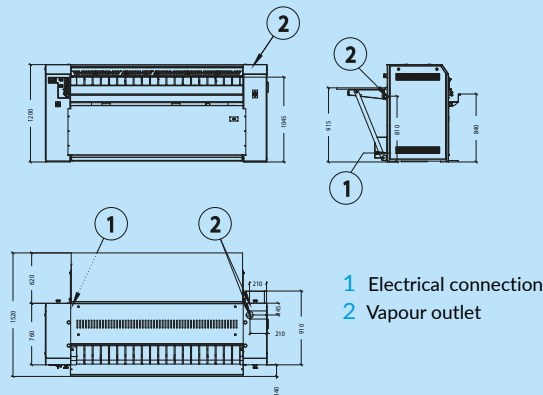

- 1 Electrical connection
- 2 Vapour outlet

ACL370 - FRONT RETURN - GAS

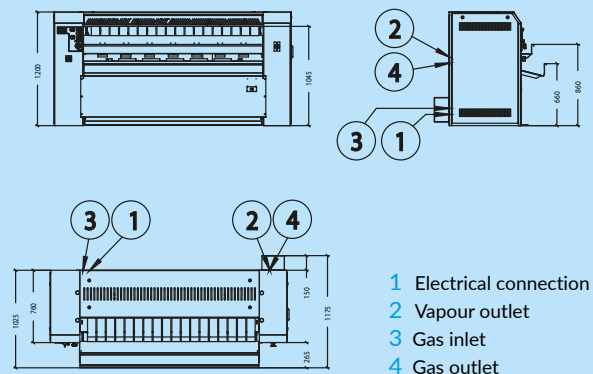

- 1 Electrical connection
- 2 Vapour outlet
- 3 Gas inlet
- 4 Gas outlet

ACL370 - REAR RETURN - GAS HEATING

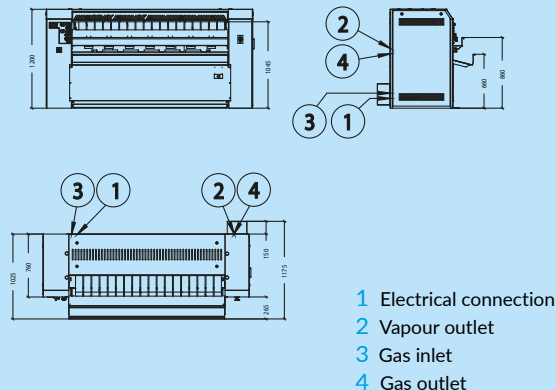

- 1 Electrical connection
- 2 Vapour outlet
- 3 Gas inlet
- 4 Gas outlet

The Primus preserves the right to change the machines and the specification in this leaflet at any time, without prior notice. Details and photographs are only for information and never binding.

www.primuslaundry.com

Primus by Alliance Laundry Systems

