

HIGHLY EFFICIENT SOFT MOUNT WASHER EXTRACTORS & DRYERS FOR FACILITY MANAGEMENT

SP
RANGE

SP 10
MOPS
10KG

SD
RANGE

SD 10
MOPS
10KG



MOP - Range



SP10

SD10

DESCRIPTION - WASHER EXTRACTOR

- Stainless steel outer and inner drum
- Industry-leading 440 G-Force extraction removes more moisture, minimizing drying times and utility costs
- Totally freestanding: can be installed on any floor and any level
- Suspension with new out-of-balance logic
- Soap box with four compartments
- Door opens 180° for easy loading and unloading
- Standard, drain valve
- Top, front and side panels standard available in anthracite grey
- Electrical heating or boiler-fed
- Special mop wash programs: mops & microfibers
- LED indication of the status of the program
- Time remaining countdown
- Compact design

DESCRIPTION - DRYER

- Galvanized steel cylinder
- Oversized lint filter located in front for easy cleaning
- Powerful exhaust blower assures short drying times and low operating costs
- Wide door opening of 180° for easy loading and unloading
- Top, front and side panels standard available in anthracite grey
- Electrical or gas heating
- 4 drying programs
- LED indication of the status of the program
- Time remaining countdown

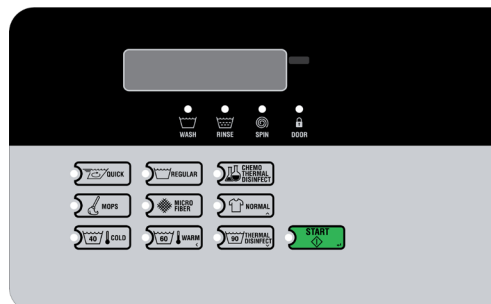

Number of Mops/batch *	SP10 MOP
Mops 100g**	90
Mops 180g**	50
Mops 200g**	45
Mops 230g**	39
Microfiber cloths 16g	563
Microfiber cloths 22g	409
Microfiber cloths 25g	350

* Numbers are indicative. Contact your Primus partner for detailed information on your requirements.

** Dimension mops 50cm x 12cm

TYPE		SP10
CAPACITY	kg	10
DRUM VOLUME	l	96,8
MOTOR		
Frequency controlled	kW	0,67
EXTRACTION SPEED	rpm	1200
G-FACTOR		440
ELECTRICAL CONNECTION		
		1x220-240V 50Hz 1x220-240V 60Hz 3x220-240V 50Hz 3x380-415V+N 50 Hz
ELECTRICAL HEATING	kW	4,8
DRAIN		
Drain valve		standard
DIMENSIONS*		
H×W×D	mm	1027×683×704
Net weight	kg	113
TRANSPORT DATA		
Volume (packed)	m ³	0,71
Packed H×W×D	mm	1150x760x860
Gross weight	kg	122

TYPE		SD10
CAPACITY	kg	10
DRUM VOLUME	l	198
ELECTRICAL CONNECTION		
		1x220-240V 50/60Hz 3x220-240V 50Hz 3x380-415V+N 50 Hz
ELECTRICAL HEATING	kW	5,2 (230V) 5,3 (400V)
GAS HEATING	kW	7,3
MOTOR POWER	kW	0,25
DIMENSIONS		
H×W×D	mm	1027×683×711
Net weight	kg	68
TRANSPORT DATA		
Volume (packed)	m ³	0,71
Packed H×W×D	mm	1150x760x860
Gross weight	kg	73

*To combine with the collector it's required a base frame (200 mm height) than can be ordered

SP10 Front View

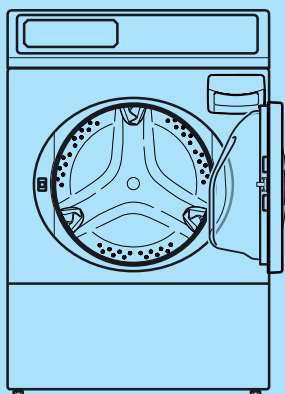

SP10 Side View

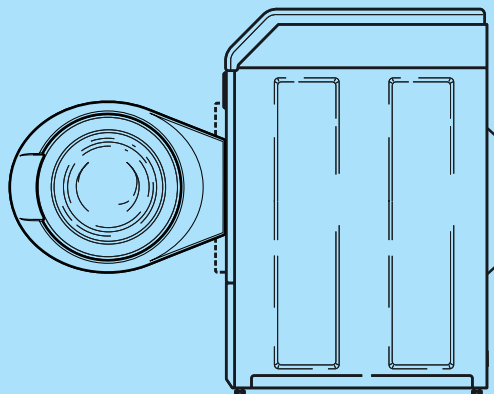

SP10 Back

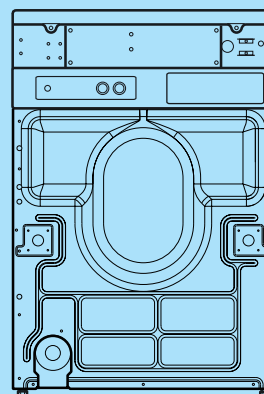

SD10 Front View

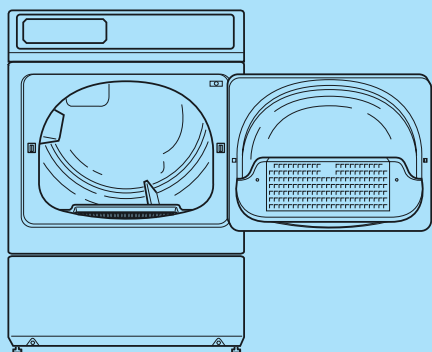

SD10 Side View

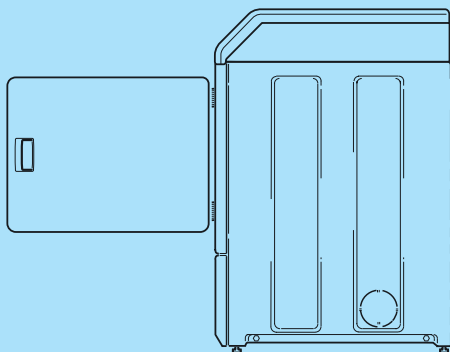

SD10 Back

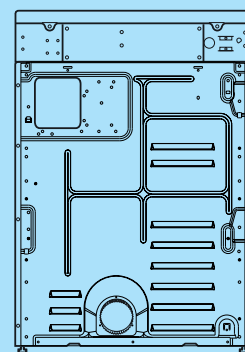

The Primus preserves the right to change the machines and the specification in this leaflet at any time, without prior notice. Details and photographs are only for information and never binding.

www.primuslaundry.com

Primus by Alliance Laundry Systems

