

# HIGHLY EFFICIENT SOFT MOUNTED WASHER EXTRACTORS

**FX  
RANGE**

FX65	FX80	FX105	FX135
6,5KG 14LB	7,5KG 18LB	10,5KG 25LB	13,5KG 30LB



## FEATURES

- Freestanding, high spin (up to 1165 rpm - FX65,FX80)
- 400G extraction speed
- Cascade Drum
- Stainless steel top and anthracite front and side panel
- Stainless steel drum and tub
- Patented soap hopper
- Liquid soap connection
- Large drain valve (Ø 76 mm)
- Easy access to all vital parts from the front
- Large door opening for easy loading & unloading

## OPTIONS

- Coin operated
- Stainless steel cabinet
- USB + RS485 plug (XControl / XControl Plus)
- Liquid soap pumps
- Water recovery kit
- Steam heating version
- Drain pump (FX65, FX80)
- 3<sup>rd</sup> water inlet

## CONTROL OPTIONS

- XControl FLEX (VEND only) - fully programmable and customizable cycles
- XControl FLEX PLUS (OPL)
  - 7", full color touch screen display
  - User-friendly screen with operating instructions built in as part of the control
  - Complete control content available in 34 languages
  - 11 wash cycles for VEND, 99 for OPL
  - 8 easy-to-understand cycle modifiers
  - Machine programming & firmware updates through cloud



INTUITIVE TOUCH  
SCREEN CONTROL



LARGE DOOR  
OPENING



LOW WATER  
AND ENERGY  
CONSUMPTION

**CONTROL  
FLEX**

**CONTROL  
FLEX+**

**cascade  
drum**

**supereco**  
washing programmes

**TRACE**

**GET AHEAD IN LAUNDRY**

TYPE		FX65	FX80	FX105	FX135
<b>INNERDRUM</b>					
Maximum capacity 1:9	kg (lb)	7 (15)	9 (20)	12 (26)	15 (33)
Capacity 1:10	kg (lb)	6,5 (13)	7,5 (18)	10,5 (24)	13,5 (31)
Volume	litres	65	75	105	135
Diameter	mm	530	530	620	620
<b>DRUM SPEED</b>					
Wash	rpm	49	49	49	49
Extraction	rpm	1165	1165	1075	1075
<b>G-FACTOR</b>					
		400	400	400	400
<b>HEATING</b>					
Electricity (standard)	kW	6 / 9	6 / 9	6 / 9 / 12	9 / 12
Steam	bar	1 - 8	1 - 8	1 - 8	1 - 8
Hot water	°C	90	90	90	90
Sound pressure level	dB (A)	< 65	< 65	< 65	< 65
Water valves connection	BSP	3/4"	3/4"	3/4"	3/4"
Water pressure	kPa	100-800	100-800	100-800	100-800
Rec. water pressure	kPa	300-500	300-500	300-500	300-500
Water inlet	l/min	20	20	20	20
Drain valve	outer Ø mm	76	76	76	76
Flow amount with drain valve	l/min	210	210	210	210
Steam valve connection	BSP	1/2"	1/2"	1/2"	1/2"
Steam pressure	kPa	100-800	100-800	100-800	100-800
<b>DIMENSIONS</b>					
Size H×W×D	mm	1135×710×740	1135×710×790	1245×795×795	1245×795×945
Net weight	kg	170	185	210	255
<b>TRANSPORT DATA</b>					
Packed H×W×D	mm	1245×750×840	1245×750×840	1345×835×840	1345×835×985
Gross weight	kg	180	200	235	275

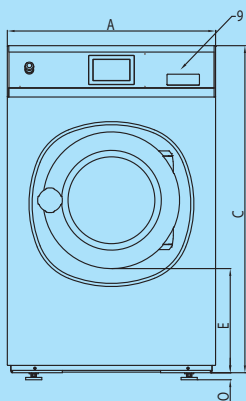

Front side

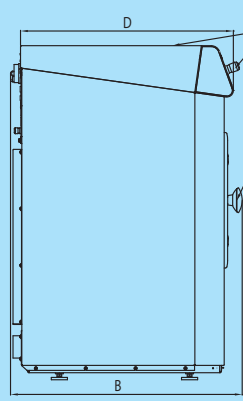

Left side

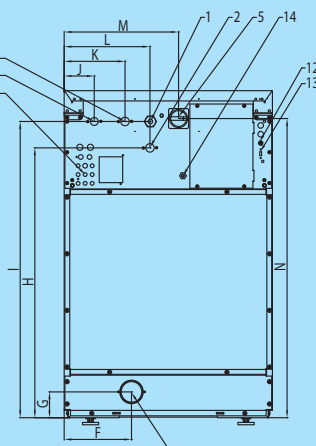

Rear side

- 1 Electrical connection
- 2 Hot water
- 3 Cold water hard
- 4 Cold water soft
- 5 Main switch
- 6 Liquid soap connection
- 7 Drain
- 8 Soap dispenser
- 9 Control panel
- 10 Button CENTRALSTOP
- 11 Door opening, FX65, FX80: Ø 330mm; FX105, FX135: Ø 410mm
- 12 Fuses
- 13 USB port
- 14 Electrical connection to liquid soap pumps

## DIMENSIONS

	A	B	C	D	E	F	G	H	I	J	K	L	M	N	O
FX65	710	740	1135	676	349	230	82	914	1004	113	218	293	390	1020	24
FX80	710	790	1135	726	349	230	88	920	1010	113	218	293	390	1020	24
FX105	795	795	1245	761	342	230	88	1030	1120	103	208	293	475	1130	24
FX135	795	945	1245	911	342	230	88	1030	1120	103	208	293	475	1130	24
	width	depth	height												

		FX80
Water consumption	l/kg	6,6
Electricity consumption	kWh/kg	0,18



\* Program No 11

The Primus preserves the right to change the machines and the specification in this leaflet at any time, without prior notice. Details and photographs are only for information and never binding.

[www.primuslaundry.com](http://www.primuslaundry.com)

